

Hanging Lite PURE LED

Cat. No. HL/L

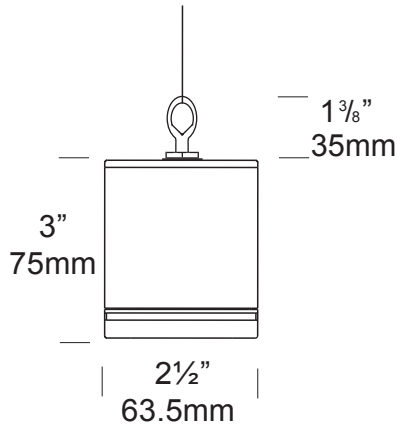

PURE LED
Pure Performance

The Hanging Lite is a single spotlight which can be easily hung from high vantage points, including trees, fences and over-hangs, providing a dramatic wash lighting effect. The luminaire is machined from a choice of 10mm thick aluminium with a UV stable powder coated finish, solid copper or 316 stainless steel with a clear, tempered, flush glass lens and high temperature silicon gaskets. Comes standard with a 3 metre cable and Stainless Steel wire.

The Hunza PURE LED system uses Cree MTG-2 chips for maximum performance and long life. Power supply options include a choice of 12 volt integral or a remote (series connection) driver. The PURE LED system incorporates HUNZA's Plug-and-Play system for easy replacement of either the LED engine or integral driver in the field. Four beam angles, and a choice of a Warm or Cool White colour temperatures are available.

*At 700mA this fitting is the equivalent of a 35w halogen fitting.

*At 1050mA this fitting is the equivalent of a 50w halogen fitting.

Luminaire	Driver mA	Beam Angle	Colour Temp	Accessories	Material/Finish
HL/L	S - Series D7 - 12v 700mA D10 - 12v 1050mA	15 - 15° TIR Lens 25 - 25° TIR Lens 38 - 38° TIR Lens 60 - 60° TIR Lens	2 - 2700K 3 - 3000K 4 - 4000K	CJK150 - Cable Joint Kit STEPF - Frosted Lens GG - Glare Guard HCL - Hex Cell Louvre	BK - Black BZ - Bronze GRN - Green STAR - Silver Star WH - White WB - White Birch DG - Dark Grey OG - Olive Green RG - Beige PR - Primrose COP - Copper SS - 316 Stainless

Ordering Example: HL/L S 15 3 CJK150 BK

HUNZA™ PURE OUTDOOR LIGHTING

HUNZA FACTORY
130 Felton Mathew Ave
Saint Johns
Auckland 1072
New Zealand

Ph: 64-9-528 9471
Fax: 64-9-528 9361
hunza@hunza.co.nz
www.hunza.co.nz

INTERNATIONAL CONTACTS:
www.hunza.co.nz/contacts.php

Specifications may change without notice.
Manufactured in New Zealand.
© 2015 Hunza Holdings Ltd.

Luminaire Construction

CNC machined from one of the following metals:

High corrosion resistant 63.5mm (2½") x 10mm (25/64") aluminium. End cap - solid aluminium 63.5mm (2½") rod, with chromate substrate and high UV resistant polyester powder coat

Colours Black, Bronze, Green, Silver Star, White, Birch, Dark Green, Olive Green, Beige, Primrose.

Copper 63.5mm (2½") x 10mm (13/32"). End cap - solid copper 63.5mm (2½") rod.

316 Stainless Steel 9mm (11/32"). End cap - solid 316 stainless steel 63.5mm (2½") rod.

Luminaire Weight

Alum .700kg (1lb 8oz)
Cop 1.470kg (3lb 3oz)
SS 1.160kg (2lb 9oz)

Features

Lens:
10mm (3/8") clear flush fit shatter resistant glass.
Lifetime Warranty.

Gaskets:
Silicone, iron impregnated 220°C (428°F).

Accessories:
Cable Joint Kit (Cat. CJK150).
Frosted Lens (Cat. STEPF).
Glare Guard (Cat. GG).
Hex Cell Louvre (Cat. HCL).

Technical Information

Standards

AS/NZS 61046
IP56/IP66 UL 1838

LED

Cree MTG-2 Plug and Play, field replaceable LED board.

Lumen Output: 600 at 1050mA
Lumens Per watt: 100 at 6 watts
CRI Warm White (3000k): 85+
Colour Temp: 2700K, 3000K and 4000K

Power Supply

Series (External) Driver

Constant current driver
Output: 6vdc at 1050mA maximum

Integral 12 Volt Driver

Hunza™ Plug and Play Driver
Input: 12vac, 7 watt total
Output: 6vdc nominal, 350 / 700 / 1005mA

Transformer

Hunza™ Wall Mount Transformer
for use with integral 12 volt driver

Reflector Beam Angles

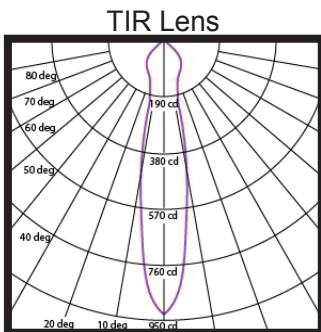

15° Angle
3000 K

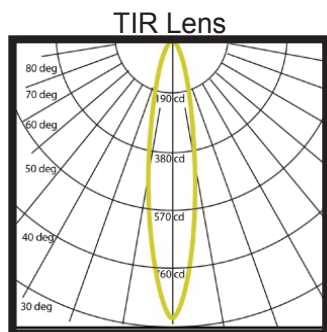

25° Angle
3000 K

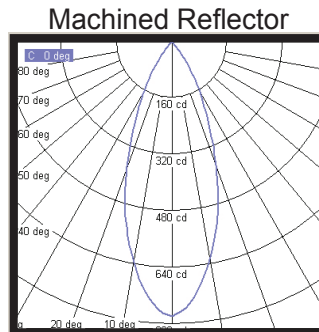

38° Angle
3000 K

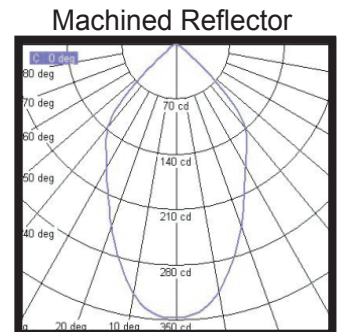

60° Angle
3000 K